

ARTWALL RECESSED
ON THE WALL WITH
PIPES EXPOSE

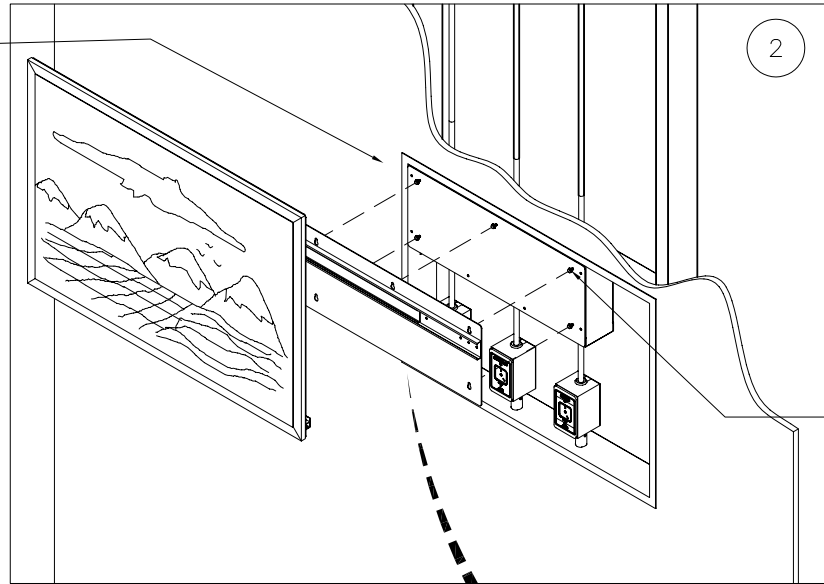

- HOOK UP THE ASSEMBLED ARTWORK & MOUNTING PLATE TO THE PANEL COVER PLATE AS SHOWN. (FIGURE-2)
- SECURE THE PLATE FOR THE SLIDER BY TIGHTENING THE FLANGE WHIZ LOCK SCREWS (USING 5/16" OPEN WRENCH).

FLANGE WHIZ
LOCK SCREWS
(PROVIDED BY AMICO)

LATCH

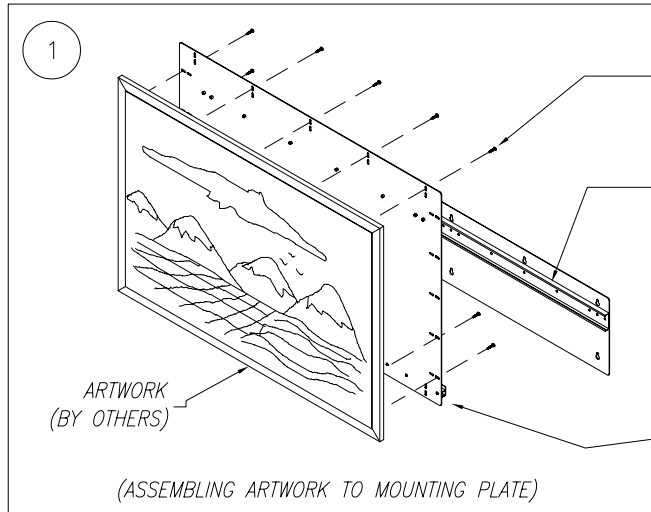

MOUNTING
HARDWARES

SLIDE RAIL
(PRE-ASSEMBLED)

ARTWORK
(BY OTHERS)

ARTWORK
MOUNTING
PLATE

(ASSEMBLING ARTWORK TO MOUNTING PLATE)

- SECURE PROPERLY THE ARTWORK TO THE MOUNTING PLATE WITH PROPER HARDWARES TO BE PROVIDED BY OTHERS. (SEE FIGURE-1)

2A

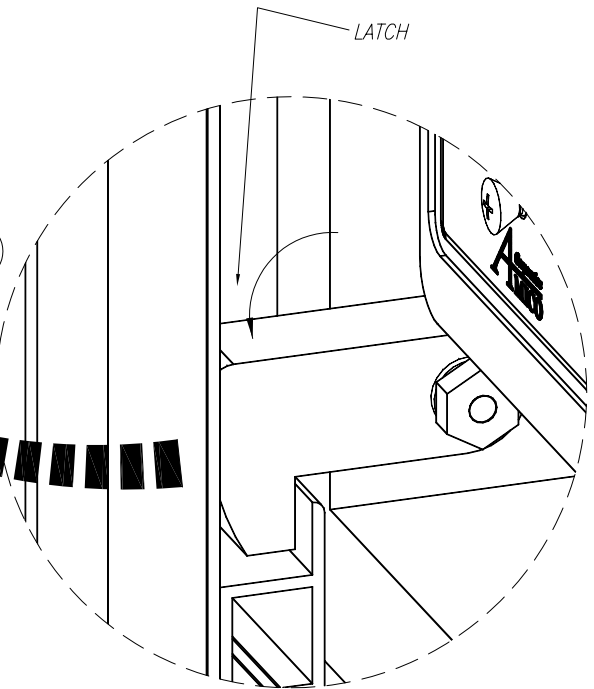

- FLIP OUT THE LATCH TOWARDS THE CATCH ON MOUNTING PLATE AS SHOWN TO STABILIZE THE OVERALL ARTWORK FRAME. (FIGURE-2A)

HOSPITAL	
LOCATION	
QTY.	(____) TYPE <u>A</u> UNITS AS SHOWN / (____) TYPE <u>B</u> UNITS OPPOSITE

MODEL NUMBER:	AMICO ARTWALL with HORIZONTAL SLIDER (LEFT/RIGHT)	
DESCRIPTION:	ASSEMBLY PROCEDURE	
DRAWING NUMBER:	021213-05	DATE: 12-13-2002
REVISION NUMBER:		DATE: